

Modu-Kleen®

Downdraft Dust Collector

SERIES

681

694

695

696



DYNAMIC AIR®
Conveying Systems



Front View - showing access door to dirty air plenum for ease of cartridge removal and inspection.

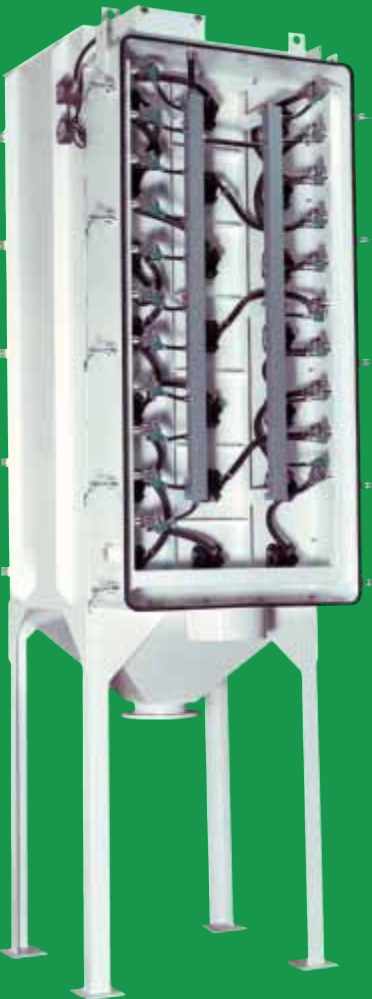

Back View - showing access door to clean air plenum for inspection and maintenance of solenoid valves wired to a NEMA 12 enclosure.

Improved performance

The Modu-Kleen® downdraft dust collector represents the latest dust collector technology developed by Dynamic Air to contain fugitive dust. This design obsoletes the conventional approach to automatic self-cleaning dust collectors. The advantages are significant with regard to performance, efficiency, filter access, energy, noise, maintenance and space requirements.

Higher material-to-air ratios

With a conventional dust collector, dust-laden air enters from the bottom of the housing and flows upward to the filters while collected particles are trying to fall into the lower collection hopper. However, with the Dynamic Air downdraft dust collector, air enters at the top of the dust collector housing and flows downward to the cartridge filters, pushing collected particulate into the collection hopper. This not only improves the filtering process itself, but also improves the material-to-air ratio. Another advantage of the downdraft design is that submicron particles, which would normally tend to stay in suspension, are now forced downward much more quickly by the incoming and downward flow of air, thus improving overall filtering efficiency and performance.

Reduces filter load, extends filter life

Since the airflow is directed downward towards the filter cartridges, the cleaning process of the Modu-Kleen downdraft dust collector is much improved over a conventional dust collector. This reduces the load on every filter cartridge and extends filter life considerably. Also, recirculation of collected particulate into the incoming air flow is greatly minimized, if not eliminated, because the air and material are both flowing in the same direction. Another benefit of the downdraft dust collector is that it usually takes up less floor space than a conventional dust collector, making it much more flexible with regard to space and plant layout.

Simple and safe filter removal

Dynamic Air's basic downdraft dust collector is designed with the cartridge filters positioned horizontally, making filter removal much easier. Personnel never have to enter the filter housing for general maintenance or for cartridge filter removal. This provides a much safer, quicker method of filter removal. For fast and easy inspections, a large, quick-opening door allows maintenance personnel to closely inspect each cartridge when required. In addition, any single cartridge can be removed without disturbing adjacent cartridges. Also, each cartridge filter has a unique built-in quarter turn bayonet mount, so no tools of any kind are required for cartridge removal.

How the Modu-Kleen downdraft dust collector works

Dust laden air is conveyed into the Modu-Kleen downdraft dust collector by either an appropriate sized negative pressure fan located at the discharge of the dust collector, or by a positive fan located on the inlet side of the dust collector. This dust-laden air enters the dust collector from the top of the housing and is directed downward to the horizontal cartridge filters. The air passes through the cartridge filter into the clean air plenum and out

to the atmosphere. The downward flow of air pushes the filtered material into the collection hopper below. The cartridge filters are periodically cleaned as a result of the pressure differential across the filter media, or on an optional timed basis. Each cartridge is cleaned automatically using high pressure bursts of compressed air, which reverse the air flow and release the filtered material into the collection hopper.

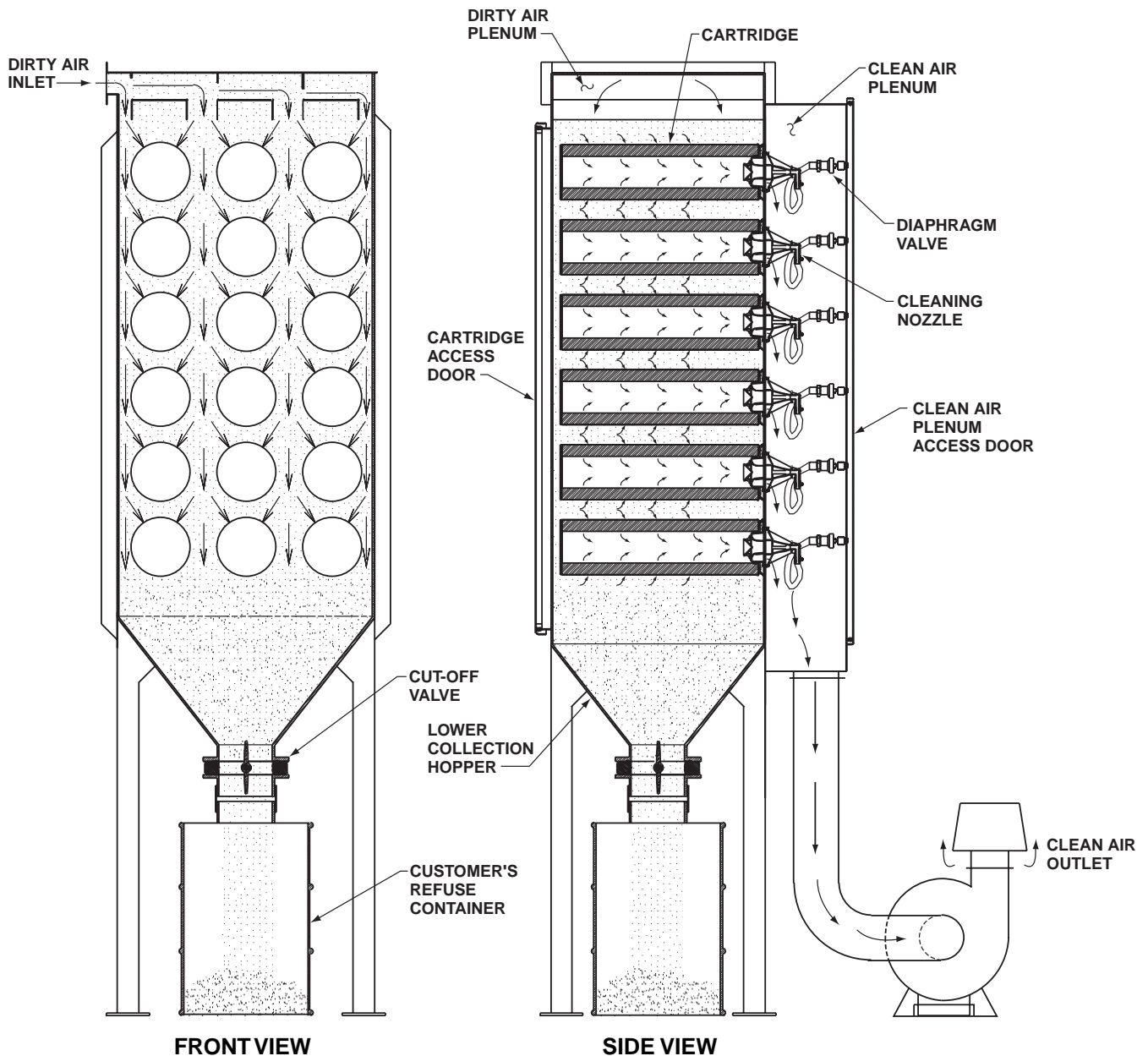

Pressure differential cleaning

During normal working operation and when the filter starts to load up with collected particulate, a pressure differential within the clean air and dirty air plenum will naturally be created. When the air pressure inside the dirty air plenum starts to increase to a predetermined setpoint, as preset within the control panel, the filter back-cleaning cycle will become energized and automatically start the cleaning cycle. This cleaning cycle will continue until the pressure drops and reaches the lower predetermined pressure setting. This method of pressure differential cleaning not only prolongs filter life but also improves filtering of the smaller particulate than otherwise possible.

Features

- Fast filter removal
- Improved efficiency
- Pressure differential cleaning
- Easy access to cartridge filters
- High material-to-air ratio
- Downdraft air flow
- Lower noise level
- Heavy-duty door seals
- Bayonet filter mounting
- Reduced space requirements
- Access door to clean air plenum
- Variety of styles available

Options

- Fan silencer
- Hopper slope
- Negative pressure fan
- Stainless steel construction
- Aluminum construction
- Hopper discharge valves
- Vibra-Jet™ bin aerators
- Cartridge media

Power requirements

Air Supply

1" or 1-1/2" NPT, 90 to 115 PSIG (6.2 to 7.9 barg) with suitable water and particulate filtration.

Electrical Supply

110/120 Volt AC, 50/60 cycle

Cartridge media



Hypoly filter

A fine denier, spun bond polyester, renewable media that combines high efficiency, excellent release characteristics and moisture tolerance for high volume and extended filter life.



Hypoly-HO filter

A fine denier, spun bond polyester, renewable media that combines high efficiency and excellent release characteristics with an enhanced surface treatment that repels water and oil.



Hypoly-PTFE filter

A high efficiency PTFE membrane laminated to the standard Hypoly media, producing a filter with extraordinary release characteristics and efficiencies on fine particles. This media choice is an excellent, effective filter for hard-to-solve filtration problems.



Polycell-120 filter

Synthetic fibers blended with cellulose to create high-durability media. Excellent abrasion and temperature resistance.



Celltex-105 filter

A gradient density cellulose base media that offers high efficiency, abrasion resistance and a dual layer with a low cure resin.



Kartex filter

Polyester needled felt with expanded PTFE membrane. Maximum efficiency capability with superior release characteristics.

Dimensions and specifications

Series 681

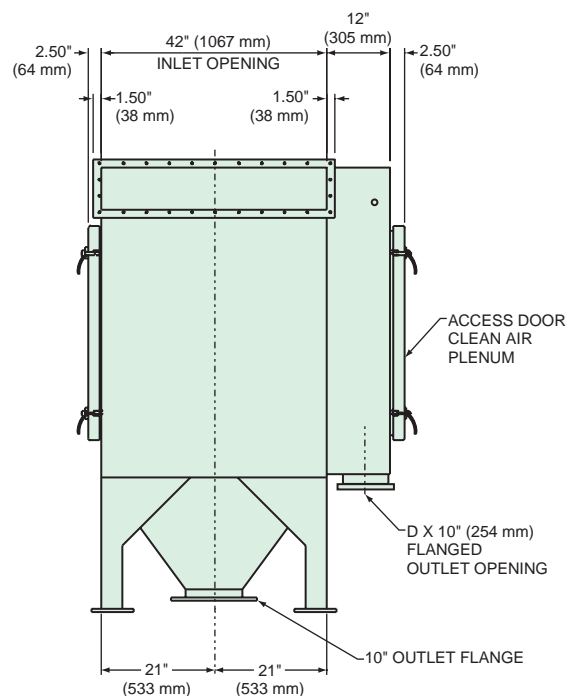
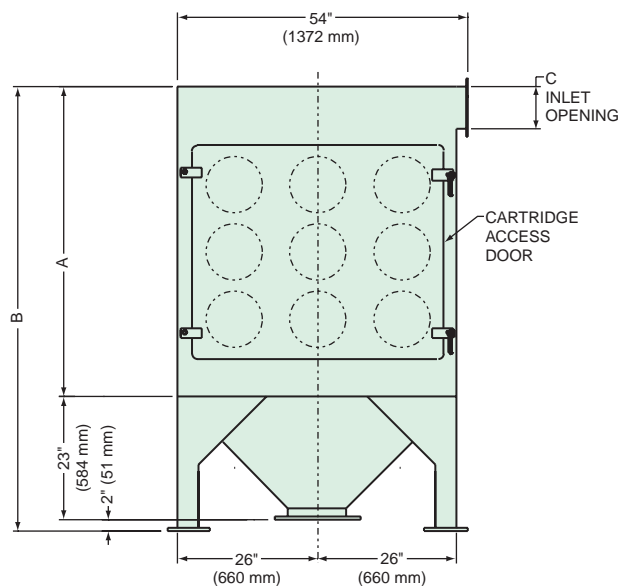

Model	Filter Area (sq. ft.)	Series 681 Dimensions								Weight	
		A		B		C*		D*		lbs.	kg.
		in.	mm	in.	mm	in.	mm	in.	mm		
900	900	58	1473	83	2108	8	203	16	406	2460	1116
1200	1200	74	1880	99	2515	9	229	21.5	546	2670	1211
1500	1500	90	2286	115	2921	10.5	267	27	686	2880	1306
1800	1800	106	2692	131	3327	11.5	292	32.5	826	3090	1402
2100	2100	122	3099	147	3734	13	330	38	965	3300	1497

Model	Filter Area (sq. ft.)	Series 694 Dimensions								Weight	
		A		B		C*		D*		lbs.	kg.
		in.	mm	in.	mm	in.	mm	in.	mm		
600	600	54	1372	74	1880	4	102	11	279	2460	1116
800	800	70	1778	90	2286	5	127	14.5	368	2570	1166
1000	1000	86	2184	106	2692	6.5	165	18	457	2680	1216
1200	1200	102	2591	122	3099	7.5	191	21.5	546	2790	1266
1400	1400	118	2997	138	3505	9	229	25	635	2900	1315

*Opening varies depending upon application.

Series 694

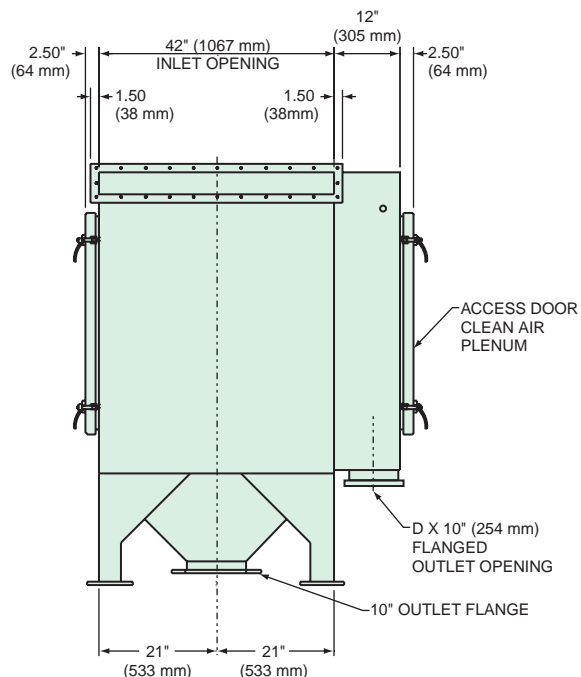
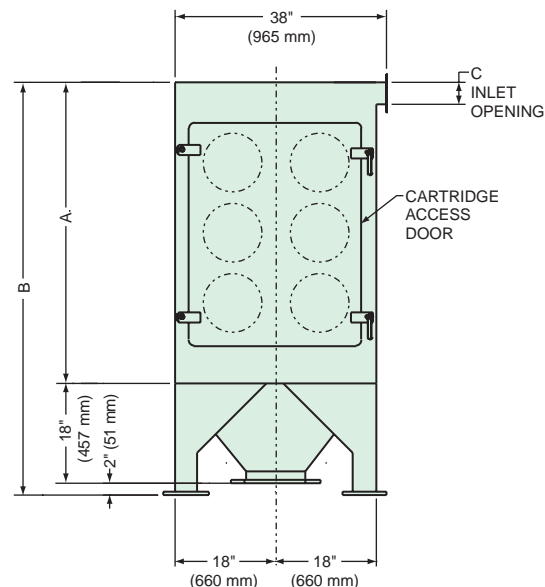

Series 695

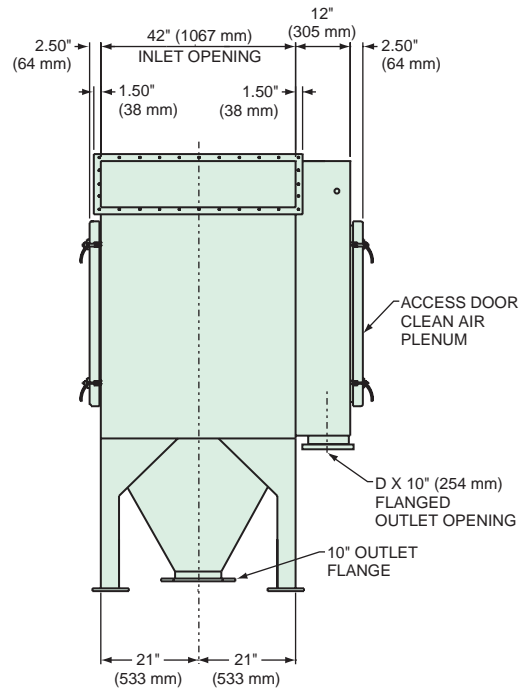
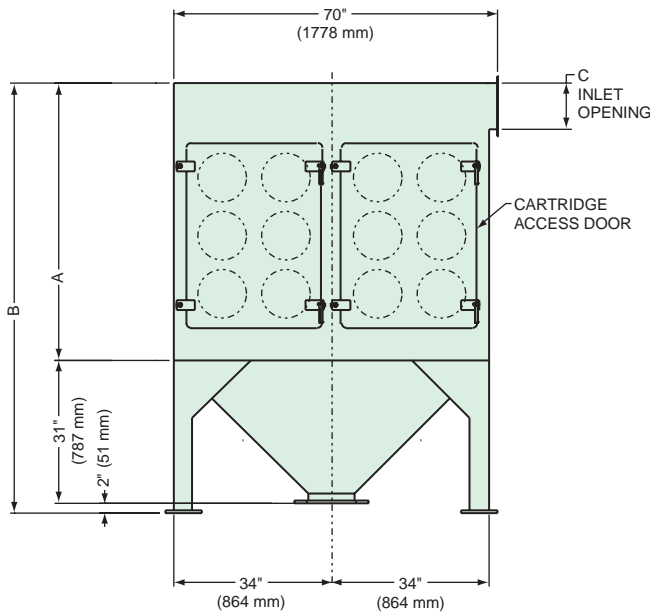

Model	Filter Area (sq. ft.)	Series 695 Dimensions								Weight	
		A		B		C*		D*		lbs.	kg.
		in.	mm	in.	mm	in.	mm	in.	mm		
1200	1200	60	1524	93	2362	10	254	32.5	826	2880	1306
1600	1600	76	1930	109	2769	11	279	43	1092	3110	1411
2000	2000	92	2337	125	3175	12.5	318	54	1372	3240	1470
2400	2400	108	2743	141	3581	13.5	343	65	1651	3470	1574
2800	2800	124	3150	157	3988	15	381	65	1651	3700	1678

Model	Filter Area (sq. ft.)	Series 696 Dimensions								Weight	
		A		B		C*		D*		lbs.	kg.
		in.	mm	in.	mm	in.	mm	in.	mm		
1800	1800	62	1575	111	2819	12	305	32.5	826	3420	1551
2400	2400	78	1981	127	3226	13	330	43	1092	3690	1674
3000	3000	94	2388	143	3632	14.5	368	54	1372	3960	1796
3600	3600	110	2794	159	4039	15.5	394	65	1651	4230	1919
4200	4200	126	3200	175	4445	17	432	65	1651	4500	2041

*Opening varies depending upon application.

Series 696

