

Change direction of air-conveyed material

The Two-Way Sliding Hose Switch by Dynamic Air Inc. is a smooth, full ported, air operated switch for use in almost any pneumatic conveying system. It is rated to 125 PSIG and is available in both mild steel or stainless steel construction. Inflatable seals at each port provide a dust tolerant seal on all ports simultaneously, plus a low friction sliding plate provides easy movement of the hose from port to port. The flexible hose is available in a wide variety of materials from abrasion resistant construction to a food grade construction. Position indicators and pressure switch sensors provide important safety alarms during operation.

Features

- Full port design
- Inflatable seals
- Position indicators standard
- Air operated
- 125 PSIG design
- Low friction
- Schedule 40 pipe standard

The Sliding Switch will handle:

- | | | |
|---------------------|---------------|------------------|
| ■ Alumina | ■ Feldspar | ■ Milk powder |
| ■ Ball clay | ■ Fine coal | ■ PVC resin |
| ■ Barite | ■ Flour | ■ Quartz |
| ■ Bauxite | ■ Fluorspar | ■ Silica sand |
| ■ Bentonite | ■ Fly ash | ■ Soda ash |
| ■ Borax | ■ Gypsum | ■ Sodium sulfate |
| ■ Calcium carbonate | ■ Iron oxide | ■ Sugar |
| ■ Cement | ■ Kaolin clay | ■ Talc |
| | ■ Lime | ■ And More |

Typical Application

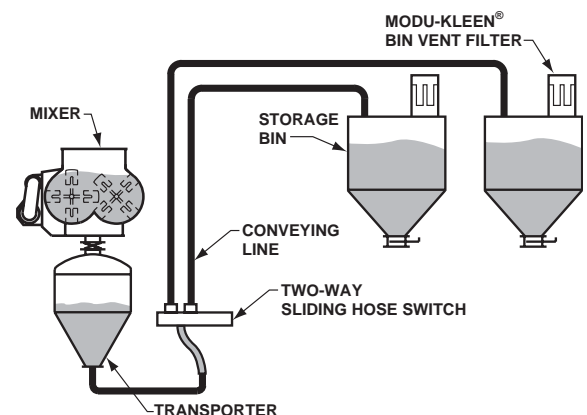

How the Two-Way Sliding Hose Switch Works

An air operator moves the slider plate of the Two-Way Sliding Hose Switch from Position #1 to Position #2. After position indicators verify the position, the inflatable seal is pressurized to provide a positive, pressure-tight connection between the slider plate and the inlet and outlet connection. In addition, pressure is monitored to ensure proper sealing prior to a conveying cycle.

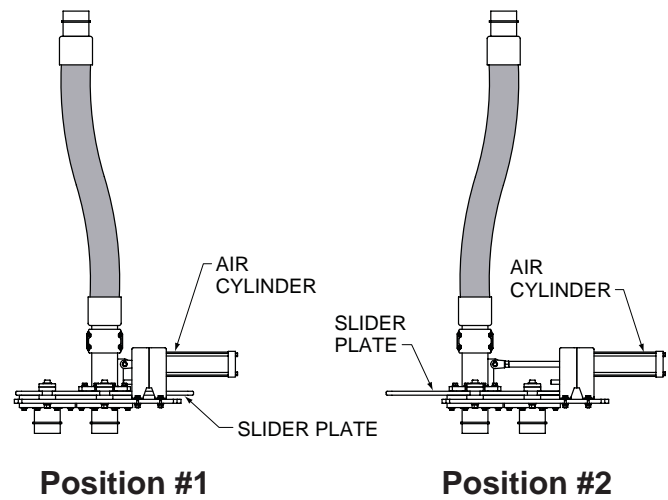

Dimensions and Specifications

Power requirements

Electrical supply:
110/120 VAC 50/60 Hz or 24 VDC

Air supply:
90-100 PSIG (6.2-6.9 barg)

Operating temperature

150° F (66° C)

Options

- Mild or stainless steel construction
- Food grade construction
- Abrasion resistant construction
- Explosion proof design
- Low voltage controls
- Sizes larger than 8"

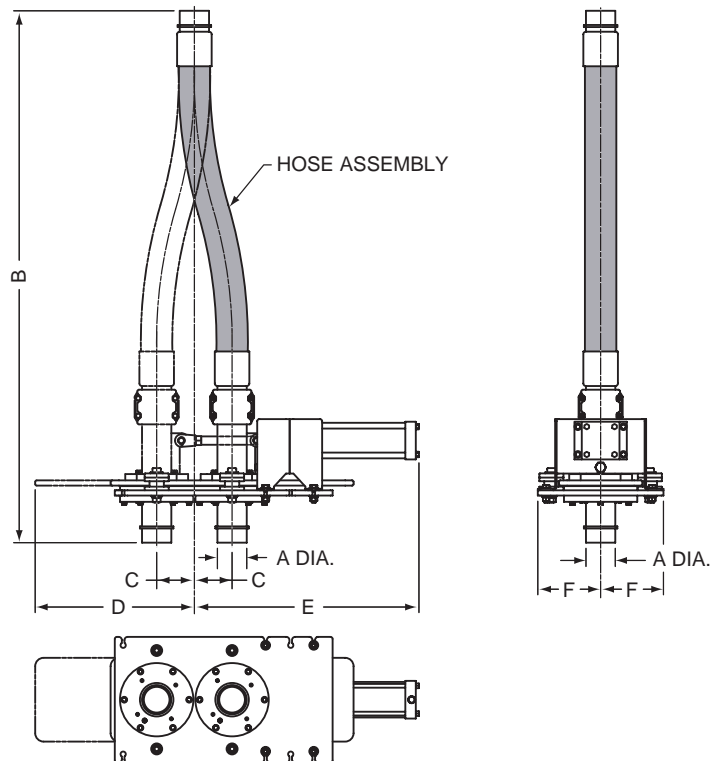

SIZE	TWO-WAY SLIDING HOSE SWITCH DIMENSIONS												APPROXIMATE WEIGHT	
	A		B		C		E		E		F			
	inches	mm	inches	mm	inches	mm	inches	mm	inches	mm	inches	mm	lbs.	kg
2"	2.38	60	63.50	1613	4.50	114	19.00	483	25.62	651	7.50	191	225	102
3"	3.50	89	63.50	1613	4.50	114	19.00	483	26.88	683	7.50	191	250	113
4"	4.50	114	76.00	1930	5.00	127	20.50	521	28.12	714	8.31	211	350	159
5"	5.56	141	89.00	2261	6.00	152	23.50	597	32.75	832	9.00	229	400	181
6"	6.62	168	113.00	2870	6.75	171	31.00	787	34.50	876	9.69	246	625	284
8"	8.62	219	138.00	3505	7.81	198	32.12	816	41.00	1041	10.88	276	835	379

Dimensions and specifications will vary according to size and configuration and are subject to change without notice.

Dynamic Air Conveying Systems® is a U.S. registered trademark of Dynamic Air Inc., St. Paul, MN USA.

© 2007, Dynamic Air Inc. • Printed in U.S.A. • Bulletin 20717

DYNAMIC AIR[®]
Conveying Systems

Corporate Headquarters

Dynamic Air Inc. • St. Paul, MN USA • +1 651 484-2900

Worldwide Offices

Australia • Brazil • China • United Kingdom

www.dynamicaire.com