



## Change direction of air-conveyed material

The Three-Way Sliding Hose Switch by Dynamic Air Inc. is a smooth, full ported, air operated switch for use in almost any pneumatic conveying system. It is rated to 125 PSIG and is available in both mild steel or stainless steel construction. Inflatable seals at each port provide a dust tolerant seal on all ports simultaneously, plus a low friction sliding plate provides easy movement of the hose from port to port. The flexible hose is available in a wide variety of materials from abrasion resistant construction to a food grade construction. Position indicators and pressure switch sensors provide important safety alarms during operation.

## Features

- Full port design
- Inflatable seals
- Position indicators standard
- Air operated
- 125 PSIG design
- Low friction
- Schedule 40 pipe standard

## The Sliding Switch will handle:

- |                     |               |                  |
|---------------------|---------------|------------------|
| ■ Alumina           | ■ Feldspar    | ■ Milk powder    |
| ■ Ball clay         | ■ Fine coal   | ■ PVC resin      |
| ■ Barite            | ■ Flour       | ■ Quartz         |
| ■ Bauxite           | ■ Fluorspar   | ■ Silica sand    |
| ■ Bentonite         | ■ Fly ash     | ■ Soda ash       |
| ■ Borax             | ■ Gypsum      | ■ Sodium sulfate |
| ■ Calcium carbonate | ■ Iron oxide  | ■ Sugar          |
| ■ Cement            | ■ Kaolin clay | ■ Talc           |
|                     | ■ Lime        | ■ And More       |

## Typical Application

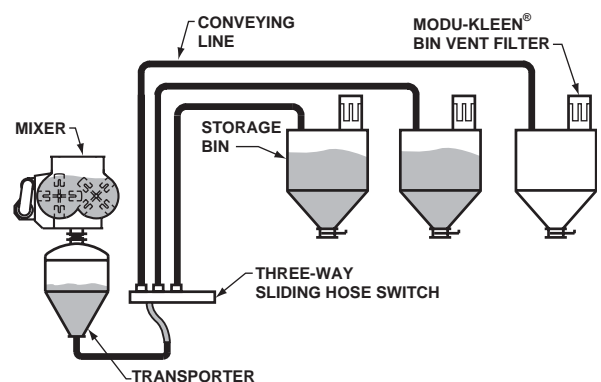

## How the Three-Way Sliding Hose Switch Works

An air operator moves the slider plate of the Sliding Hose Switch from Position #1 to Position #2 to Position #3. After position indicators verify the position, the inflatable seal is pressurized to provide a positive, pressure-tight connection between the slider plate and the inlet and outlet connection. In addition, pressure is monitored to ensure proper sealing prior to a conveying cycle.

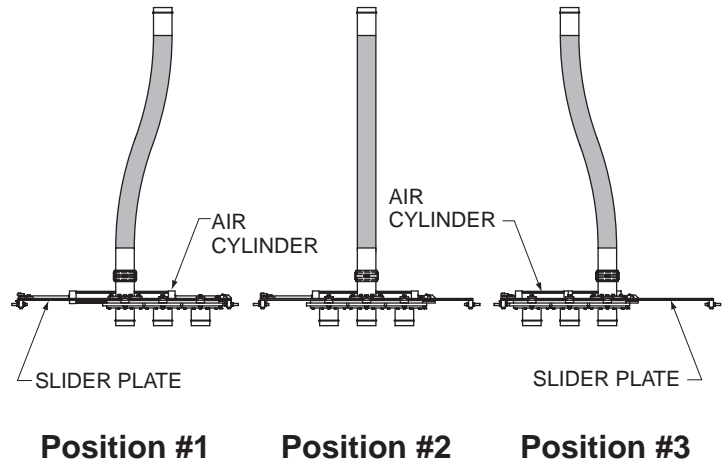

## Dimensions and Specifications

### Power requirements

Electrical supply:  
110/120 VAC 50/60 Hz or 24 VDC

Air supply:  
90-100 PSIG (6.2-6.9 barg)

Operating temperature  
150° F (66° C)

### Options

- Mild or stainless steel construction
- Food grade construction
- Abrasion resistant construction
- Explosion proof design
- Low voltage controls
- Sizes larger than 8"

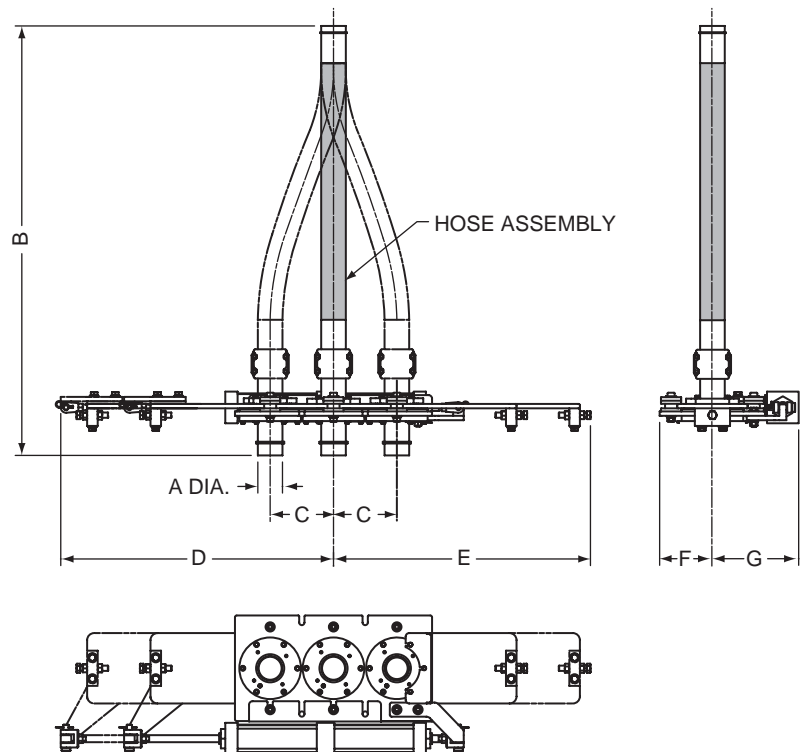

SIZE	THREE-WAY SLIDING HOSE SWITCH DIMENSIONS														APPROXIMATE WEIGHT	
	A		B		C		D		E		F		G		lbs.	kg
	inches	mm	inches	mm	inches	mm	inches	mm	inches	mm	inches	mm	inches	mm		
2"	2.38	60	75.00	1905	9.00	229	38.75	984	36.50	927	7.50	191	12.25	311	320	145
3"	3.50	89	72.00	1829	9.00	229	38.75	984	36.50	927	7.50	191	12.25	311	350	159
4"	4.50	114	87.00	2210	10.00	254	41.00	1041	38.62	981	8.03	204	12.78	325	450	204
5"	5.56	141	100.00	2540	12.00	305	49.00	1245	48.50	1232	8.75	222	14.50	368	600	272
6"	6.62	168	112.00	2845	13.50	343	54.00	1372	54.00	1372	9.68	246	17.03	433	840	381
8"	8.62	219	136.00	3454	15.62	397	62.62	1591	60.75	1543	10.88	276	17.81	452	1120	508

Dimensions and specifications will vary according to size and configuration and are subject to change without notice.

Dynamic Air Conveying Systems® is a U.S. registered trademark of Dynamic Air Inc., St. Paul, MN USA.

© 2007, Dynamic Air Inc. • Printed in U.S.A. • Bulletin 20720



### Corporate Headquarters

Dynamic Air Inc. • St. Paul, MN USA • +1 651 484-2900

### Worldwide Offices

Australia • Brazil • China • United Kingdom

[www.dynamicair.com](http://www.dynamicair.com)