



Single shaft model

Reduces lumps for improved material handling

The Tuffer[®] aerator/lump breaker effectively reduces moist, semi-moist, or dry solids down to near grain size. The fast moving breaker bars help to reduce lumps with ease and aerate the material. The result is a more consistent particle size and a fluffier bulk solid. Material will gravity feed and flow easier, improving overall handling efficiency.

Simple design eliminates high friction

The Tuffer aerator/lump breaker consists of an independently driven shaft powered by a v-belt drive system. The shaft has a number of heavy duty breaker bars mounted close together to control the particle size desired. This simple free-wheeling

design eliminates high friction forces, lowering horsepower requirements and the need for complex parts and synchronization.

For even finer particle breakdown, a perforated screen deck can be added just below the rotating breaker bars to limit the particle size and to prevent any larger than desired lumps from passing through.

The Tuffer aerator/lump breaker is available in various sizes and capacities to suit most process requirements. The low profile design permits installation in new and existing systems.

Features

- Abrasion resistant breaker bars
- Rugged construction
- V-belt drive
- Low profile design
- Self cleaning
- Low cost
- Fixed shear bars
- Single or double shafts depending upon size.
- Adjustable packing gland seal for high temperature material

Typical application

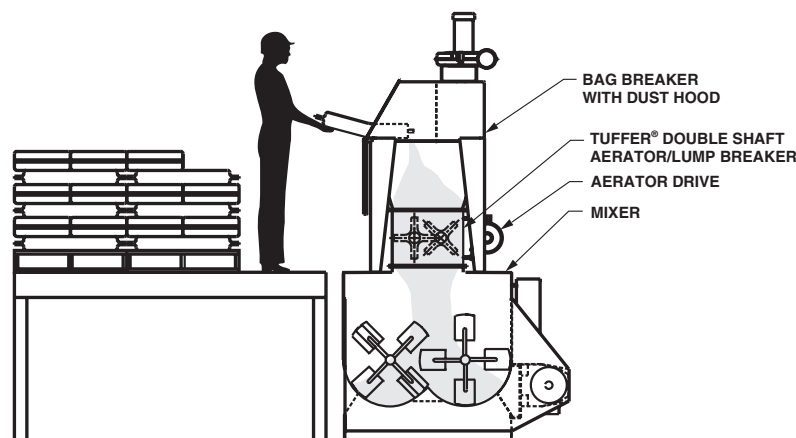

The Tuffer aerator/lump breaker will handle:

- | | |
|---------------------|------------------|
| ■ Alumina | ■ Gypsum |
| ■ Ball clay | ■ Iron oxide |
| ■ Barite | ■ Kaolin clay |
| ■ Bauxite | ■ Lime |
| ■ Bentonite | ■ Milk powder |
| ■ Borax | ■ Molding sand |
| ■ Calcium carbonate | ■ PVC resin |
| ■ Cement | ■ Quartz |
| ■ Feldspar | ■ Silica sand |
| ■ Fine coal | ■ Soda ash |
| ■ Fluorspar | ■ Sodium sulfate |
| ■ Fly ash | ■ Sugar |
| | ■ Talc |
| | ■ And more |

How the Tuffer aerator/lump breaker works

To control the inlet flow, material must be fed into the Tuffer aerator/lump breaker by a feeding device, such as a screw or vibratory feeder or manually fed evenly. When the material is fed into the Tuffer aerator/lump breaker, a double set of counter-rotating breaker bars drive the bulk solids through to break up the lumps of material on a double shaft model. On a single shaft model, the breaker bars rotate against fixed pins. The Tuffer aerator/lump breaker uses the centrifugal force generated by the closely spaced bars to reduce the bulk solids to a smoother, fluffier consistency.

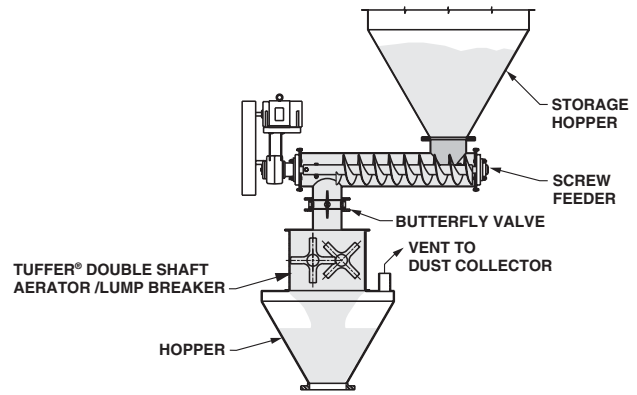

Dimensions and specifications

Options

- Stainless steel construction
- Special finishes
- Variable speed drive
- Timing belt drive
- Special voltages and frequencies
- Outboard bearings
- Air purged seals
- High temperature construction

Power requirements:

Standard Operating Voltage:
230/460 VAC 3 phase 60 Hz

Standard Operating Temperature:
150° Fahrenheit/65° Celsius

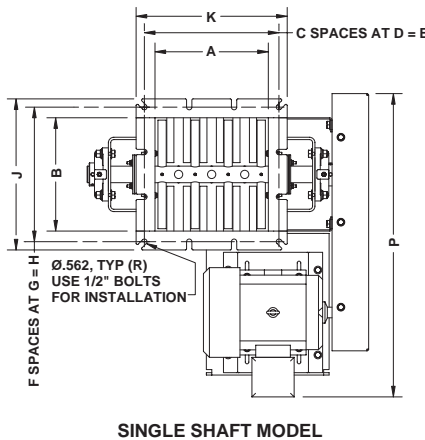

SINGLE SHAFT MODEL

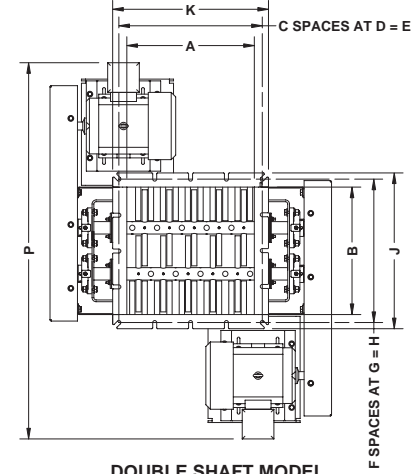

DOUBLE SHAFT MODEL

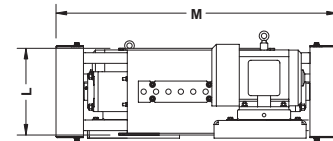
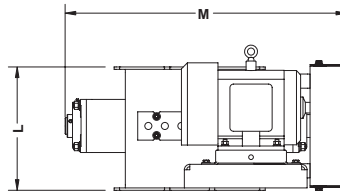

TUFFER AERATOR/LUMP BREAKER SERIES 697 DIMENSIONS														inches	millimeters	
SINGLE SHAFT MODEL																
Model	A	B	C	D	E	F	G	H	J	K	L	M	P	R		
1212	12	12	3	4.750	14.25	3	4.750	14.25	16	16	13.06	29.81	32.12	12		
	305	305		121	362		406	406	332	757	816					
1218	18	12	4	5.062	20.25	3	4.750	14.25	16	22	13.06	35.81	32.12	14		
	457	305		129	514		406	559	332	910	816					
1224	24	12	6	4.375	26.25	3	4.750	14.25	16	28	13.06	41.81	32.12	18		
	610	305		111	667		406	711	332	1062	816					
1236	36	12	9	4.250	38.25	3	4.750	14.25	16	40	13.06	53.81	32.12	24		
	914	305		108	972		406	1016	332	1367	816					
DOUBLE SHAFT MODEL																
1818	18	18	4	5.062	20.25	4	5.062	20.25	22	22	12.25	39.73	53.12	16		
	457	457		129	514		559	559	311	1009	1349					
1824	24	18	6	4.375	26.25	4	5.062	20.25	22	28	12.25	45.73	53.12	20		
	610	457		111	667		559	711	311	1162	1349					
1836	36	18	9	4.250	38.25	4	5.062	20.25	22	40	12.25	57.73	53.12	26		
	914	457		108	972		559	1016	311	1466	1349					

Specifications subject to change without notice.

Dynamic Air Conveying Systems® and TUFFER® are registered trademarks of Dynamic Air Inc., St. Paul, MN, USA.

© 2007, Dynamic Air Inc.

Printed in U.S.A. • Bulletin 20721



Corporate Headquarters

Dynamic Air Inc. • St. Paul, MN USA • +1 651 484-2900

Worldwide Offices

Australia • Brazil • China • United Kingdom

www.dynamicair.com