



Convey and switch hard-to-handle materials

The Dynamic Air Switch Receiver diverts material from on-line conveying into a receiving bin or silo. Because of the unique full-flow design, the Switch Receiver can handle even cohesive, abrasive or hard-to-handle materials. The Switch Receiver provides total clean out, preventing cross-contamination of materials conveyed.

Compact, rugged design requires little maintenance

The Switch Receiver has few moving parts and is designed for minimal maintenance. When it becomes necessary to replace worn parts, the top cover of the Switch Receiver is easily removed, providing easy access without lifting or moving the unit from the bin or silo. The inflatable seals are dirt tolerant and resist material build-up. They require no lubrication and are easy to replace if damaged.

Features

- Full flow design
- Full cleanout
- Rugged, dust-tight construction
- Positive positioning
- Low maintenance
- Quiet operation
- Top access cover
- Pre-piped

Options

- 2", 3", 4", 5", 6", 8", and 10"
- Ceramic lining
- Stainless steel
- Food grade construction

Fixed pivot shaft provides positive positioning

Exact positioning of the Switch Receiver is important, especially when handling abrasive or fragile materials. Positive positioning is achieved by use of a fixed pivot shaft with adjustable mechanical stops. In the "thru" position, material flows smoothly, with no edges or corners impeding flow. In the "bin" position, the curved baffle neatly diverts the flow into the bin or silo below. This smooth, even flow reduces wear caused by abrasives and minimizes degradation of fragile materials.

Typical application

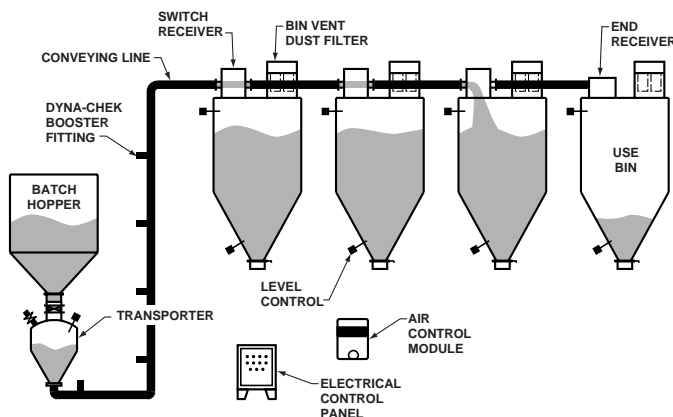

The Switch Receiver will convey:

- | | | |
|---------------------|---------------|------------------|
| ■ Alumina | ■ Dolomite | ■ Quartz |
| ■ Ball clay | ■ Feldspar | ■ Salt |
| ■ Barite | ■ Fine coal | ■ Silica sand |
| ■ Bauxite | ■ Fluorspar | ■ Soda ash |
| ■ Bentonite | ■ Fly Ash | ■ Sodium sulfate |
| ■ Borax | ■ Glass batch | ■ Sugar |
| ■ Calcium carbonate | ■ Kaolin clay | ■ Talc |
| ■ Cement | ■ Lime | ■ And More |

How the Switch Receiver works

Each Switch Receiver is permanently positioned on top of a receiving bin or silo as part of the conveying line. When the Switch Receiver is in Position #1, a wear-resistant curved baffle diverts the conveyed material into the bin or silo below.

When switching from bin loading (Position #1) to the thru position (#2), the inflatable seals deflate to allow the curved baffle to rotate, aligning the straight thru port precisely with the conveying line. The inflatable seals are then pressurized to form an air-tight seal during conveying.

The Switch Receiver can be repositioned between cycles. When the air operator is energized, it rotates the curved baffle on a fixed pivot shaft with adjustable mechanical stops for positive positioning. The inflatable seals provide an air-tight seal in both positions, preventing leaking and cross-contamination. Residual material drops into the bin below so that no material build-up remains after conveying.

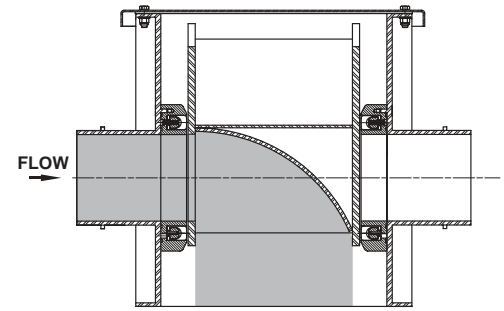

POSITION #1 (BIN OR DIVERTED)

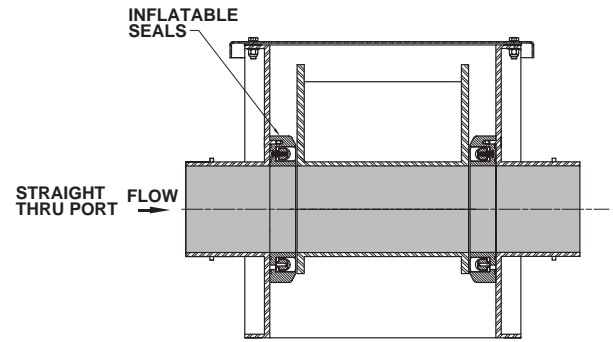

POSITION #2 (THRU)

Dimensions and specifications

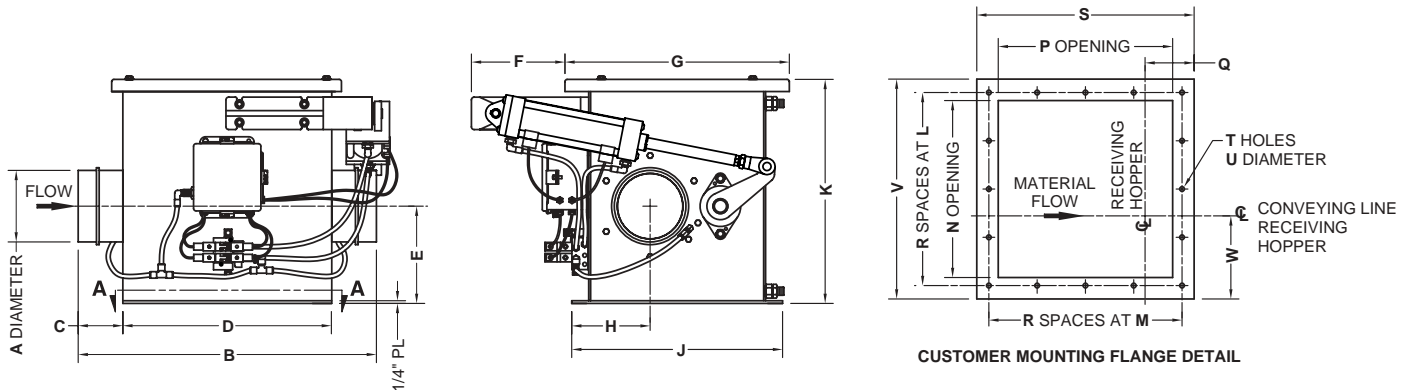

| SIZE | DIMENSIONS - INCHES (MILLIMETERS) | | | | | | | | | | | | | | | | | | | | |
|------|-----------------------------------|-----------------|---------------|----------------|----------------|---------------|----------------|----------------|----------------|----------------|---------------|---------------|----------------|----------------|---------------|---|----------------|----|----------------|----------------|----------------|
| | A | B | C | D | E | F | G | H | J | K | L | M | N | P | Q | R | S | T | U | V | W |
| 2" | 2.38 (60) | 27.56 (700) | 4.12 (105) | 19.31 (490) | 9.00 (229) | 8.69 (221) | 20.75 (527) | 7.25 (184) | 19.50 (495) | 20.75 (527) | 4.50 (114) | 4.50 (114) | 16.50 (419) | 16.25 (413) | 4.50 (114) | 4 | 20.25 (514) | 16 | 0.44 (11) | 20.50 (521) | 7.75 (197) |
| | 3.50 (89) | 27.56 (700) | 4.12 (105) | 19.31 (490) | 9.00 (229) | 8.69 (221) | 20.75 (527) | 7.25 (184) | 19.50 (495) | 20.75 (527) | 4.50 (114) | 4.50 (114) | 16.50 (419) | 16.25 (413) | 4.50 (114) | | | | 20.25 (514) | 16 | 0.44 (11) |
| 4" | 4.50 (114) | 27.56 (700) | 4.12 (105) | 19.31 (490) | 9.00 (229) | 8.69 (221) | 20.75 (527) | 7.25 (184) | 19.50 (495) | 20.75 (527) | 4.50 (114) | 4.50 (114) | 16.50 (419) | 16.25 (413) | 4.50 (114) | 4 | 20.25 (514) | 16 | 0.44 (11) | 20.50 (521) | 7.75 (197) |
| | 5.56 (141) | 27.56 (700) | 4.12 (105) | 19.31 (490) | 9.00 (229) | 8.69 (221) | 20.75 (527) | 7.25 (184) | 19.50 (495) | 20.75 (527) | 4.50 (114) | 4.50 (114) | 16.50 (419) | 16.25 (413) | 4.50 (114) | | | | 20.25 (514) | 16 | 0.44 (11) |
| 6" | 6.62 (168) | 30.56 (776) | 4.12 (105) | 19.31 (490) | 9.00 (229) | 8.69 (221) | 20.75 (527) | 7.25 (184) | 19.50 (495) | 20.75 (527) | 4.50 (114) | 4.50 (114) | 16.50 (419) | 16.25 (413) | 4.50 (114) | 4 | 20.25 (514) | 16 | 0.44 (11) | 20.50 (521) | 7.75 (197) |
| | 8.62 (219) | 42.00 (1067) | 7.50 (191) | 27.00 (686) | 12.50 (318) | N/A | 30.50 (775) | 10.50 (267) | 30.00 (762) | 30.75 (781) | 4.75 (121) | 4.25 (108) | 26.00 (660) | 23.00 (584) | 5.00 (127) | | | | 6 | 27.00 (686) | 24 |
| 10" | 10.75 (273) | 42.00 (1067) | 7.50 (191) | 27.00 (686) | 12.50 (318) | N/A | 30.50 (775) | 10.50 (267) | 30.00 (762) | 30.75 (781) | 4.75 (121) | 4.25 (108) | 26.00 (660) | 23.00 (584) | 5.00 (127) | 6 | 27.00 (686) | 24 | 0.56 (14) | 30.00 (762) | 10.50 (267) |
| | | | | | | | | | | | | | | | | | | | | | |

Specifications subject to change without notice.

Bulletin 921-3 (dm)
© 2004, Dynamic Air Inc. • Printed in U.S.A.



Corporate Headquarters
Dynamic Air Inc. • St. Paul, MN USA • +1 651 484-2900

Worldwide Offices
Australia • Brazil • China • United Kingdom

www.dynamicair.com