



## Blends large batches

The Blendcon® air blender is one of the fastest, most efficient blenders available for mixing large batches of dry bulk materials. It can typically blend a 300 cubic foot batch in just four minutes, and can handle batches up to 200 tons in capacity.

By producing large, consistent, homogeneous batches, the Blendcon air blender simplifies material handling and quality control, and increases productivity.

## Fast, homogeneous blending

The Blendcon air blender uses compressed air to lift, turn and tumble dry materials, utilizing the high kinetic energy released when compressed air is allowed to expand rapidly to atmospheric pressure. Compressed air is pulsed into the material in an upward circular pattern. This blending method is so effective that very few pulses are required to complete the blending cycle. Blending is fast and thorough. The ratio of horsepower to material blended is very low, resulting in high efficiency.

The discharge cone valve helps to eliminate dead spots during blending and substantially reduces segregation during discharge. There are no mixer arms or blades to wear out or clog, making the Blendcon air blender ideal for blending abrasive materials which would shorten the life of a conventional blender.

## Better cleanout between batches

The smooth interior silo surfaces help prevent buildup. There are no mixing blades, tubes, or pipes to trap material, making it easier to perform any required cleanout between different batches.

## Variable blending control

The blending action and intensity are controlled by the duration and frequency of air pulses, and by the pressure and volume of air. These variables are fully adjustable to achieve optimum results for your specific application.

## Easily installed

The Blendcon blending head can be installed on an existing or customer supplied silo, or it can be ordered with a standard silo or custom-designed silo to suit your application.

## Features

- Fast, gentle homogeneous blending
- Easier silo cleanout
- Anti-segregation cone
- Variable blending control
- Blends abrasive materials
- Low energy consumption
- Uses standard compressed air
- Low shear

## The Blendcon air blender will handle

- Plastic pellets
- Glass batch
- Flour mixes
- Chemical compounds
- Cement grouts
- Food products
- Foundry additives
- And most dry materials

## Batch blending - how it works

When batch blending with the Blendcon air blender, the following components are required:

- A Blendcon blending head which includes sixteen air-operated injector valves, injector nozzles, head sensing device, air operated cone valve and necessary air controls
- A blending silo
- A 100 PSIG compressed air supply
- A dust filter to separate the material being blended from the exhausted compressed air
- An electrical control panel for automatic sequencing of all functions of the blending and discharging cycles
- A compressed air surge tank to accumulate compressed air used for blending

The air blender operates as follows:

### Fill cycle

1. The fill cycle begins when the discharge cone valve is in the down, or closed, position and, the blending silo is completely empty.
2. Material enters and fills the silo by a pneumatic conveying system or other means, and the silo fills to a predetermined batch level.

### Blend cycle

3. The blend cycle begins when a level control or load cell indicates the blending silo is filled to its proper level.
4. Compressed air is injected in pulses through sixteen injector nozzles upward, and in a circular pattern. The pulses of compressed air normally range from a short "on" time of about two seconds or less to a longer "off" time, which can exceed sixty seconds. This blending action lifts the center core of bulk solids upward, and, at the same time, moves the perimeter bulk solids downward, turning and tumbling the material to a homogeneous blend.
5. During the blend cycle the exhausted compressed air normally exits the blending silo by means of a continuous cleaning bag or cartridge filter, which contains and recycles the collected fine particles back into the batch being blended.

### Discharge cycle

6. After a preset blending time, when the blending is complete, the discharge cone valve moves to the up, or open, position, allowing the homogeneously blended batch of material to discharge by gravity. The discharge cone valve also helps to prevent material from segregating during discharging.
7. The discharge cone cone valve remains in the up, or open, position until the silo is completely empty.

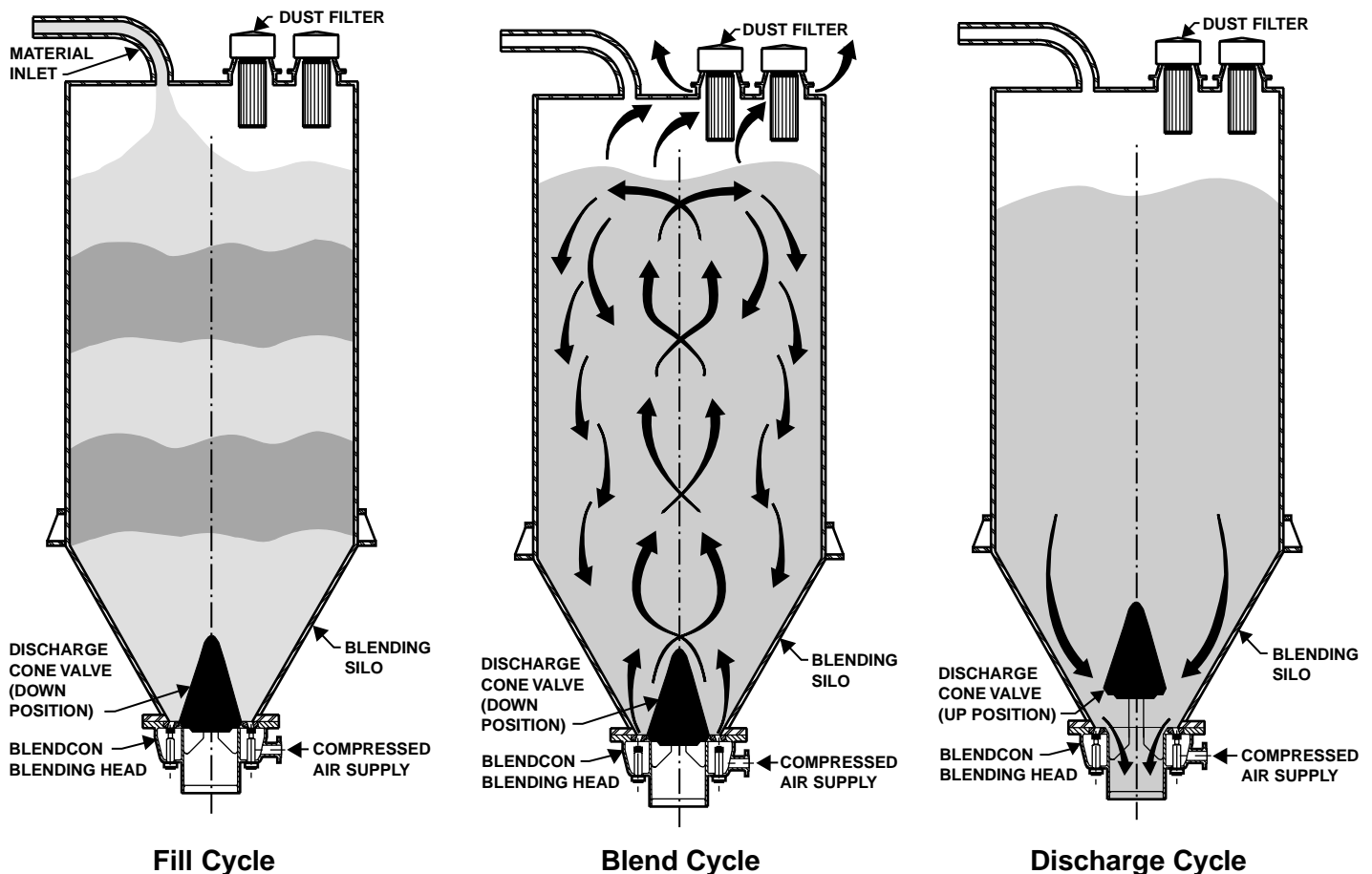

## Continuous blending - how it works

When continuous blending with the Blendcon air blender, the following components are required:

- A Blendcon blending head which includes sixteen air-operated injector valves, injector nozzles, and necessary air controls
- A blending silo
- A 100 PSIG compressed air supply
- A dust filter to separate the material being blended from the exhausted compressed air
- An air-operated outlet butterfly valve
- An electrical control panel for automatic sequencing of all functions of the blending and discharging cycles
- A compressed air surge tank to accumulate compressed air used for blending

The air blender operates as follows:

1. Material continuously enters the silo by a pneumatic conveying system or other means.

### Blend cycle

2. With the outlet butterfly valve closed, compressed air is injected in pulses through sixteen injector nozzles, moving and lifting the material upward, and in a circular pattern. The pulses of compressed air normally range from a short

“on” time of about two seconds or less to a longer “off” time, which can exceed sixty seconds. This blending action lifts the center core of bulk solids upward, and, at the same time, moves the perimeter bulk solids downward, turning and tumbling the materials to a homogeneous blend.

3. During the blend cycle the exhausted compressed air normally exits the blending silo by means of a continuous cleaning bag or cartridge filter, which contains and recycles the collected fine particles back into the batch being blended.

### Discharge cycle

4. The control system monitors the surge hopper level controls. When the material level in the surge hopper reaches the low level control, the system waits for the completion of the blending pulse and then opens the outlet butterfly valve to discharge material into the surge hopper below. When the material in the surge hopper reaches the high level control, the outlet butterfly valve closes and the blending cycle continues.

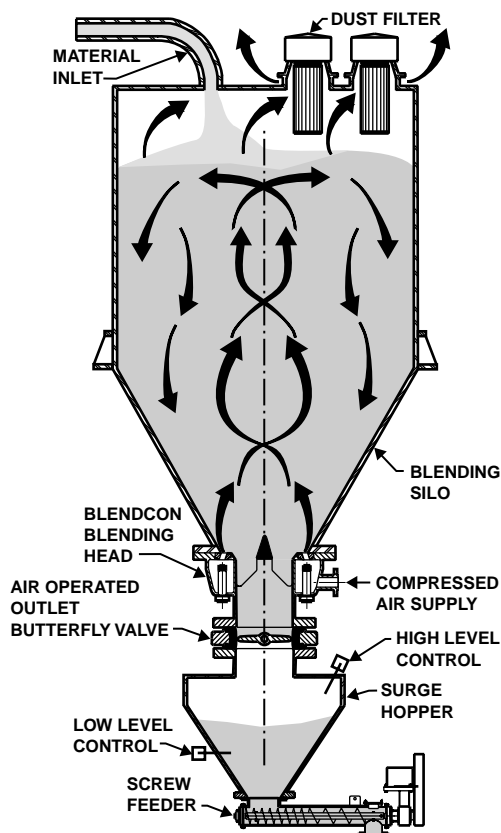

Blend Cycle

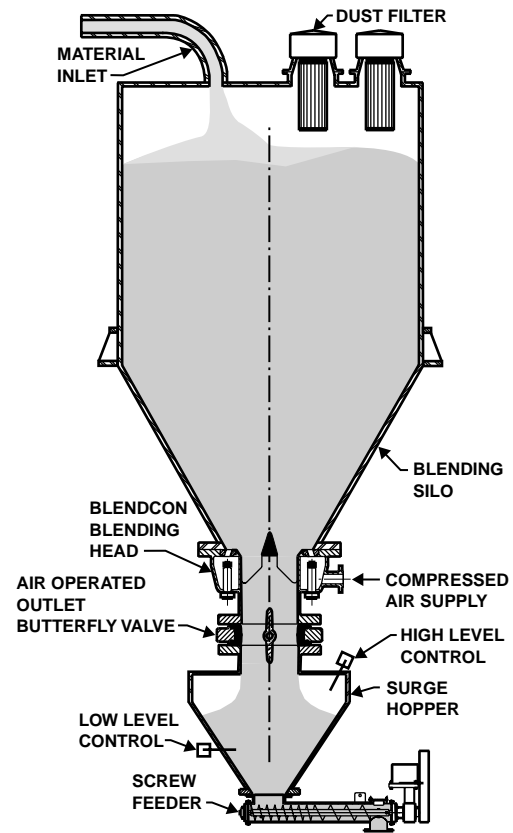

Discharge Cycle

# Dimensions and specifications - Silo with blending head

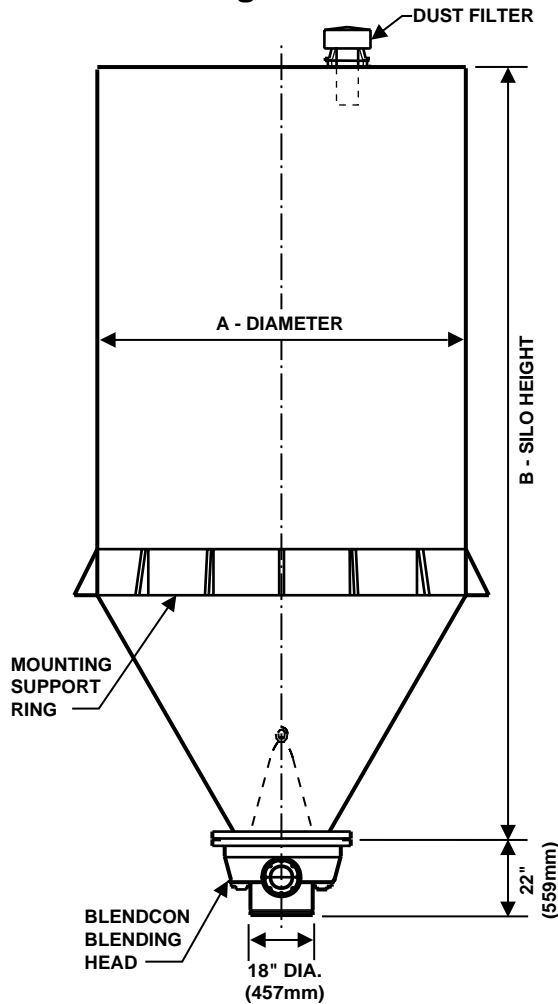

Side View - Blending Head in Silo

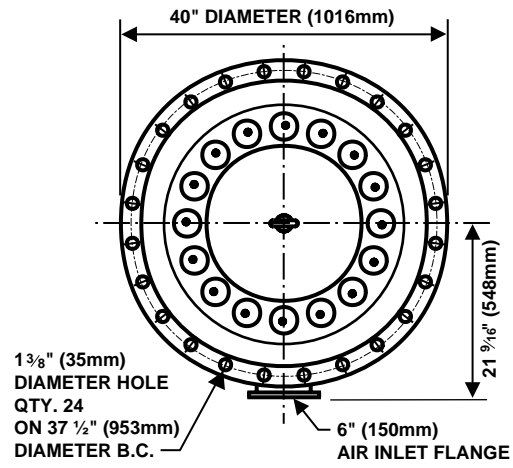

Top View - Blending Head

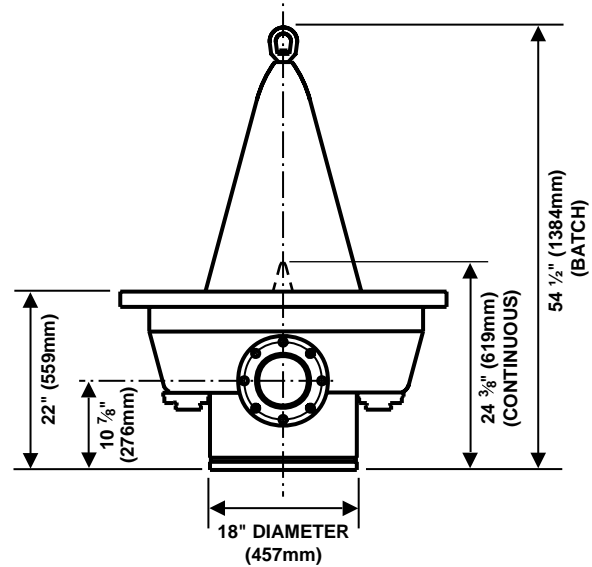

Side View - Blending Head

Capacity		"A" Diameter		"B" Height	
Cubic Feet	Cubic Meters	Feet	Meters	Feet	Meters
500	14.2	8	2.438	20.50	6.25
600	17.0	8	2.438	23.50	7.16
700	19.8	8	2.438	26.50	8.08
800	22.7	10	3.048	22.50	6.86
900	25.5	10	3.048	24.50	7.47
1000	28.3	10	3.048	26.50	8.08
1500	42.5	12	3.657	28.25	8.61
2000	56.6	12	3.657	35.00	10.67
2500	70.8	12	3.657	41.75	12.73
3000	85.0	12	3.657	48.50	14.78

Testing facilities are available to determine exact performance specifications and operating parameters.

Specifications subject to change without notice.

## Temperature

Minimum: -20° Fahrenheit (-29° Celsius)  
Maximum: 150° Fahrenheit (66° Celsius)

## Pressure

Maximum: 125 PSIG (8.62 barg)

## Options

- Food grade construction
- 304/316 stainless steel construction
- Continuous blending
- Flange outlet

*Dynamic Air Conveying Systems® and Blendcon® are registered trademarks of Dynamic Air Inc., St. Paul, Minnesota.*

© 2003, Dynamic Air Inc.

Printed in U.S.A. • Bulletin 9719-1 (2/7/03) (UK 3/08)

**DYNAMIC AIR**  
Conveying Systems

### Corporate Headquarters

Dynamic Air Inc., 1125 Willow Lake Blvd., St. Paul, MN 55110-5193  
Phone (651) 484-2900 • Fax (651) 484-7015

### United Kingdom

Dynamic Air Ltd., 26 Peverel Drive, Granby, Milton Keynes, MK1 1QZ  
Phone +44 (0)1908 622344 • Fax +44 (0)1908 646633

[www.dynamicair.com](http://www.dynamicair.com)